

Design Poul Henningsen

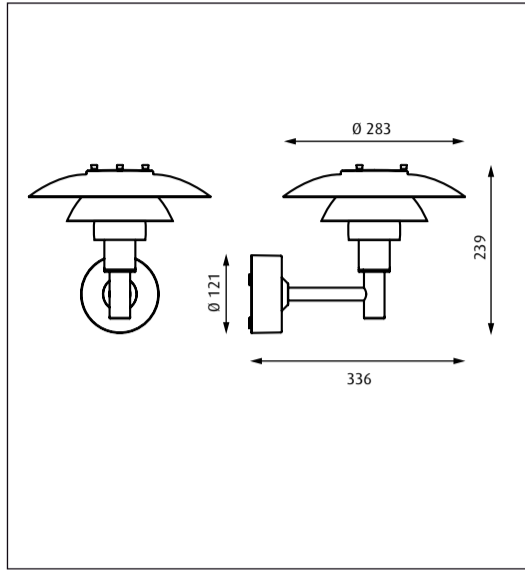

38267-11

Lyskilde Light source Leuchtmittel Ljuskälla Sorgenti luminose Source lumineuse Fuente de luz	Spænding/frekvens Voltage/frequency Spannung/frequenz Spänning/frekvens Tensione/frequenza Voltage/frequence Tensión/ frecuencia	Vægt Weight Gewicht Vikt Peso/ingombro Poids Peso	Isolationsklasse Electric shock protection Schutzklasse Isolationsklass Classe di isolamento Protection au choc électrique Clase de aislamiento	Tæthedsklasse Ingress protection Ingress protection Kapslingsklass Grado di protezione Indice de protection Clase de protección
<b>1x60W E27</b> <small>More info <a href="http://www.louispoulsen.com">www.louispoulsen.com</a></small>	<b>Max 230V/50Hz</b>	<b>2,5 kg</b>	<b>Cl. I</b>	<b>IP 44</b>

## DA

Støv aftørres med en tør, blød klud. Fedtpletter og lignende kan fjernes med en blød klud opvredet i lunkent vand (<50° C) tilsat mildt rengøringsmiddel. Brug aldrig rengøringsmidler med slibemiddel eller opløsningsmidler.

## EN

Wipe off dust with a dry, soft cloth. Remove greasy spots etc. with a soft cloth dampened in lukewarm water (<50° C) with a mild detergent. Never use detergents containing abrasives and solvents.

## DE

Staub bitte mit einem trockenen, weichen Lappen abwischen. Fettflecke und dgl. mit einem feuchten, in lauwarmem Wasser (<50° C) mit mildem Reinigungsmittel ausgewungenen Lappen entfernen. Niemals Reinigungsmittel mit Schleifmittel oder Lösungsmittel verwenden.

## SV

Lampan dammtorkas med en torr, mjuk trasa. Fettfläckar tas bort med ljummet vatten (<50° C) utblandat med mildt rengöringsmedel. Använd aldrig rengöringsmedel som innehåller slipmedel eller lösningsmedel.

## IT

Pulire la polvere esterna con un panno morbido e asciutto. Rimuovere macchie di grasso ecc. con un panno morbido inumidito in acqua tiepida (<50° C) e con un detergente leggero. Non usare mai detergenti contenenti abrasivi o solventi.

## FR

Essuyez la poussière avec un chiffon sec et doux. Enlevez les points de salete etc. Avec un chiffon doux impregne d'eau claire tiède et de detergent doux. Ne jamais utiliser de detergents contenant des abrasifs et des solvants.

## ES

Limpiar con paño seco y suave. Quitar manchas de grasa y otras con paño suave humedecido con agua templada (<50° C) con detergente poco agresivo. Nunca use detergentes que contengan abrasivos y disolventes.

## CN

### PH 3-2½ WALL MAX60W

用干燥和柔软的布擦去灰尘。用柔布沾温水(低于50度)和温和型的清洁剂除去油腻点。切勿使用含磨料和溶解性的清洁剂。



3 mm  
6 mm

38267-I1

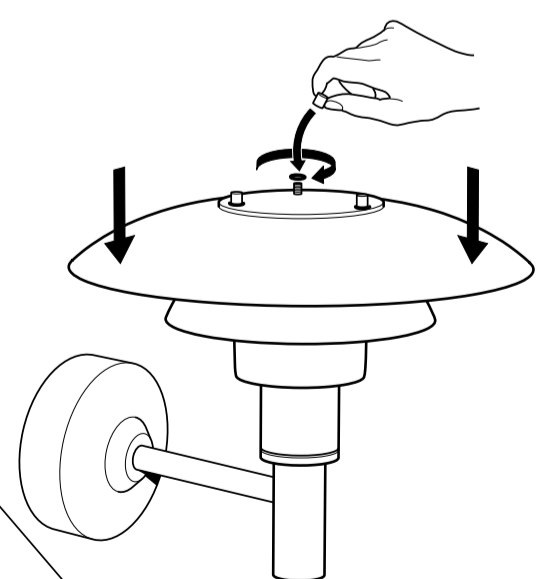
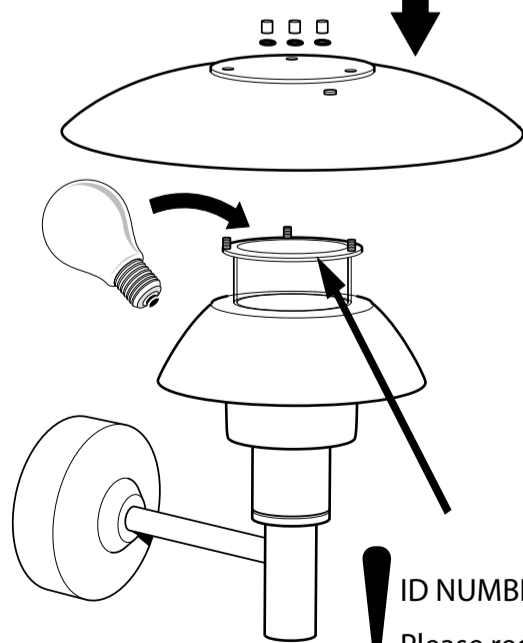
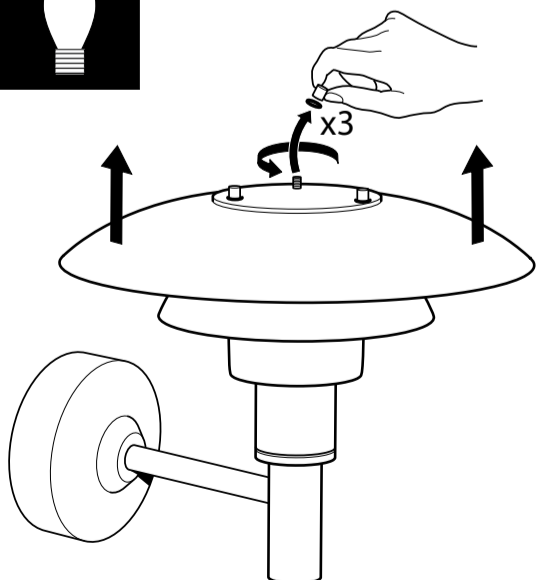
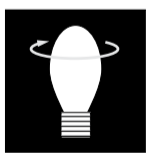
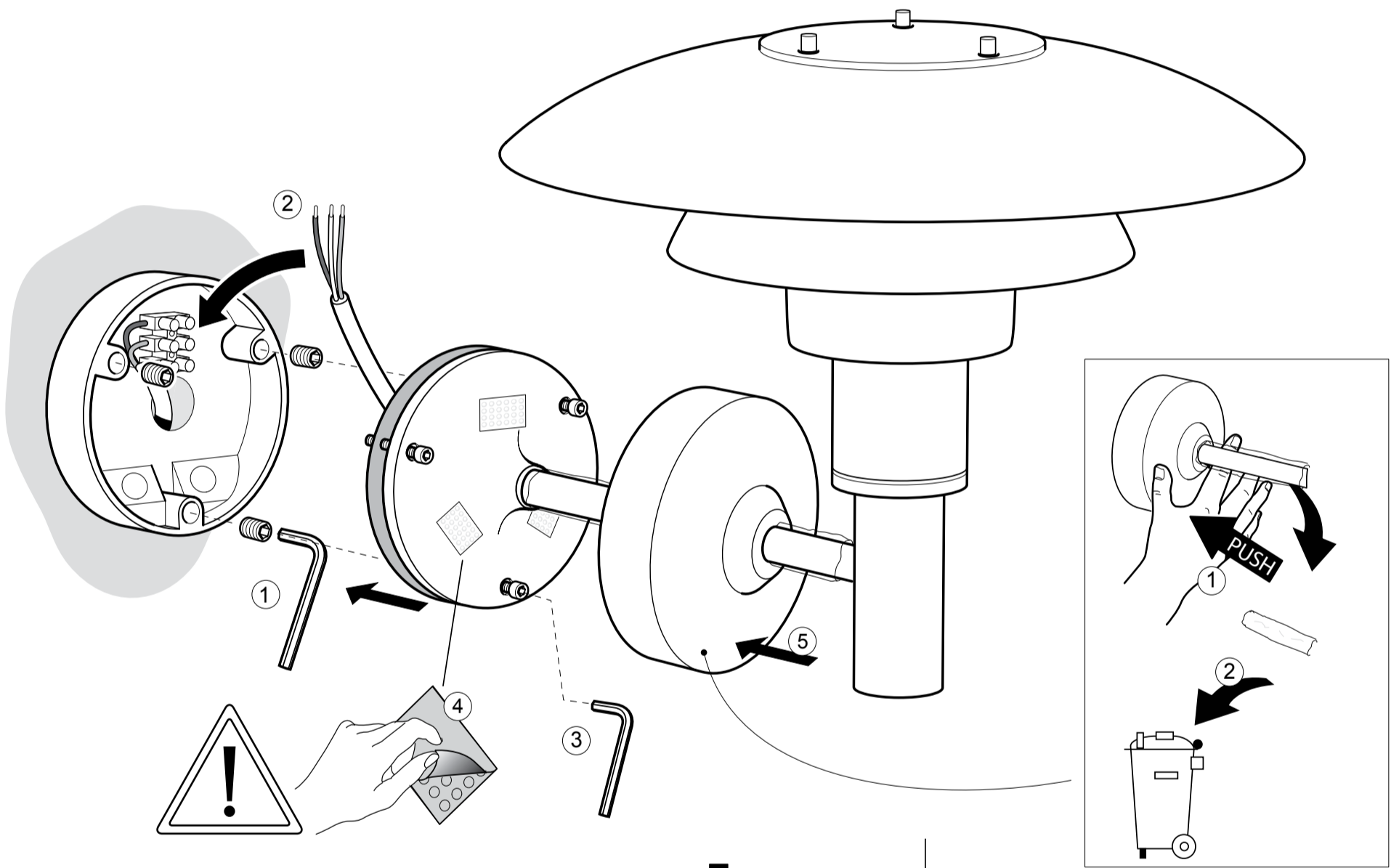
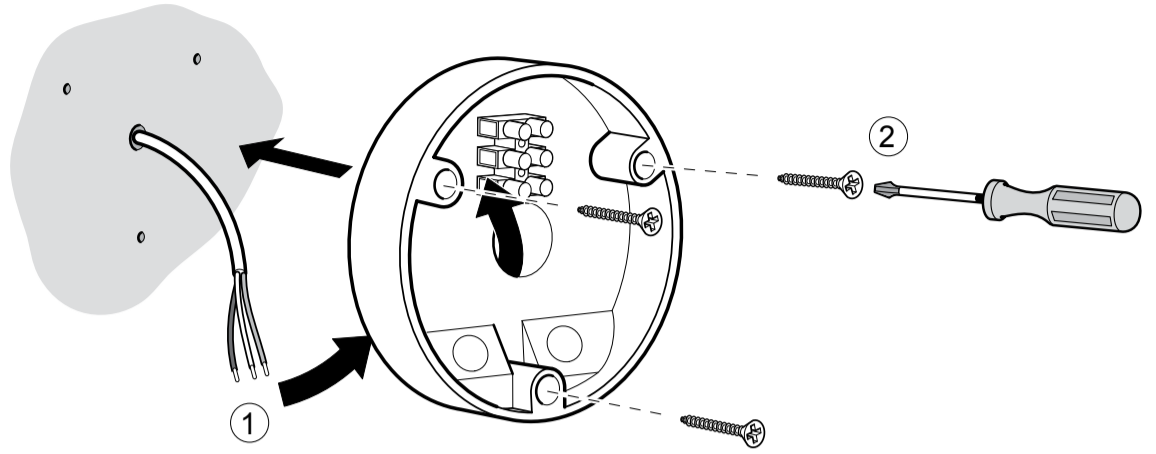
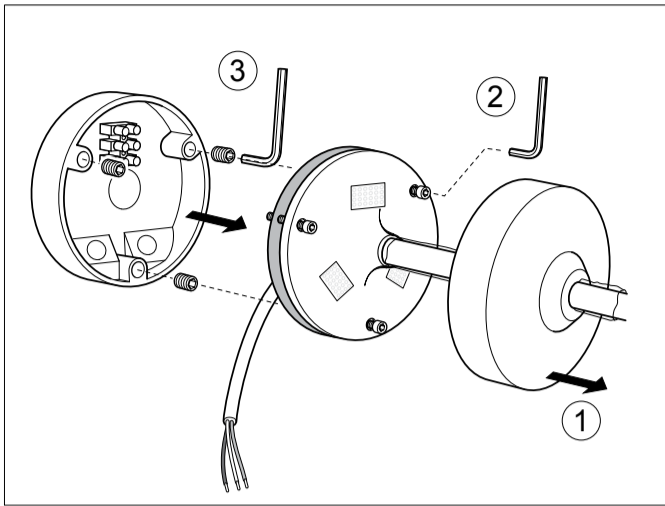

ID NUMBER: \_\_\_\_\_  
Please register ID number at  
[www.louispuolsen.com](http://www.louispuolsen.com)